

# Medium & Thick Wall Journal Bearings

DHB 14

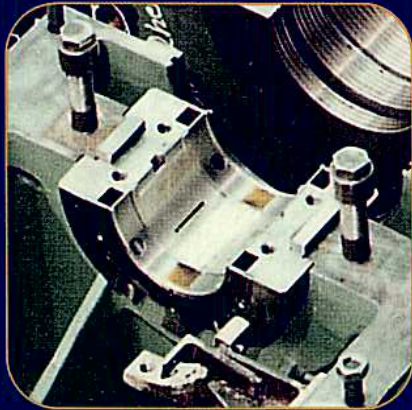





Range of NS medium and KS thick wall bearings from 50 to 600mm shaft diameter.

**FRONT COVER**

*Steam turbine casing showing NS medium wall bearing fitted to receive shaft.*

# Contents

<b>1</b>	<b>Benefits</b>	<b>4</b>
<b>2</b>	<b>Product Summary</b>	<b>4</b>
<b>3</b>	<b>Choice of Bearing</b>	<b>5</b>
<b>4</b>	<b>Lubrication</b>	<b>7</b>
<b>5</b>	<b>Performance Monitoring</b>	<b>8</b>
<b>6</b>	<b>Installation</b>	<b>8</b>
<b>7</b>	<b>Higher Performance Materials</b>	<b>11</b>
<b>8</b>	<b>Special Designs and Related Products</b>	<b>12</b>
<b>9</b>	<b>Size Tables</b>	<b>15</b>
<b>10</b>	<b>Enquiry Data Sheet</b>	<b>21</b>



# 1

## Benefits of Specifying Waukesha NS & KS Medium and Thickwall Journal Bearings

- Specifically designed for turbomachinery and other fast/large rotating equipment.
- Adaptability and compactness.
- Specialist design advice and performance data.
- Lower costs from standardised ranges.
- Solutions based on long experience worldwide.
- Technical support and service, including full rotor dynamic studies.
- New materials extend performance limits and operate in hostile environments.
- Ongoing R & D commitment.
- Designed and made to ISO 9001:2000.

# 2

## Product Summary

The NS & KS medium and thick wall metric bearing ranges are designed for pressure oil lubricated rotating machinery, mainly in the power range from 1MW upwards and operating at sliding speeds from 5 to 75 m/s.

A wide variety of plain journal bearing sizes and proportions up to 710mm shaft size is available as can be seen from the size tables.

This handbook shows bearings supplied in halves. They can also be made in bush form where assembly allows.

Bearings traditionally have had cylindrical bores, but at higher speed there is a need for stability. Reasons to use various profiles are summarised in table 1.

Parts are made steel backed lined with tin based whitmetal (Babbitt) to specification ISO SnSb8Cu4. Equivalent specifications are BS 3332/A and SAE 12. 40% Sn Al, Cu Pb and polymer linings can be used to extend performance limits or withstand high ambient temperatures. See section 7.

Thrust capacity up to 0.35 MPa can be provided on KSC thick wall bearings, or by separate thrust washers where medium wall designs are chosen.

For higher thrust loads and fast sliding speeds tilting pad bearings may need to be considered. See section 8 on related products.

For shaft sizes above 700 and up to 1200mm bearings are designed and made to your or our drawings. Again see section 8.

Bearings can also be made to inch dimensions. Details on request.

*With all these alternatives it is an important part of Waukesha Bearings service to advise on the best solution for any machine; this includes estimated operating data, dynamic coefficients and contract drawings. Full rotor dynamic studies are also undertaken.*

## Choice of Bearing

### Medium or Thick Wall

The NS and KS bearing ranges have been widely used for 30 years in demanding applications. KS parts are made to DIN 7473/6 standard. The benefits of each type are as follows:

MEDIUM WALL	THICK WALL
<p>Less radial space needed</p> <p>Wider choice of lining materials</p> <p>Made as interchangeable halves</p> <p>Spares easy to handle and transport</p> <p>Lower stock holding costs for spares</p>	<p>Include location and thrust faces</p> <p>Housing design and execution has less effect on bearing</p> <p>Can repair by relining whitmetal (Babbitt)</p>

### Diameter and Length

Shaft diameter is usually fixed in advance by torque or stability considerations.

Load capacity depends directly on uninterrupted bearing length for which there are 3 standard ratios to diameter, 0.5, 0.75 and 1.0. Other ratios can also be supplied, to optimise performance.

As an initial guide radial load divided by projected area should not exceed 4 MPa and in most cases it is advisable to design below this limit, especially if the load is present at start up and stopping. See also section 4 - hydrostatic jacking.

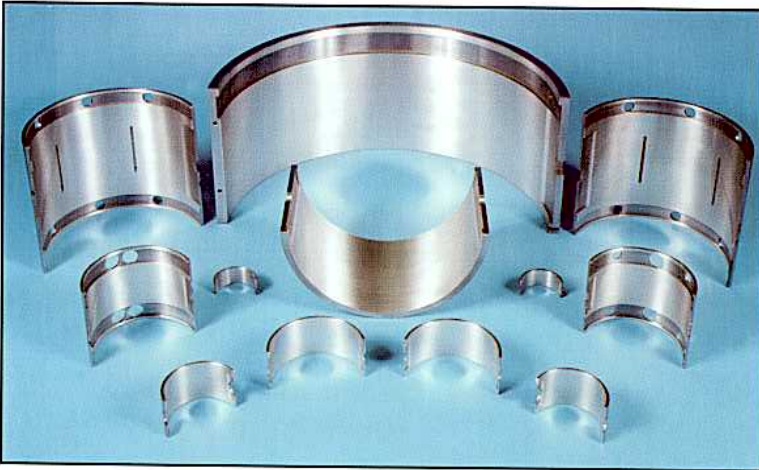

Medium wall bearings.



Thick wall bearings



# Choice of Bearing

Continued

## Bore Profiles and Dynamic Characteristics

At high speeds and light loads stability becomes a problem. Special bore profiles such as lemon bore,





offset halves or lobes can give better shaft control and avoid oil film whirl.

Where machines approach or run through critical speeds bearing oil films are often the major source of

damping. The right choice of bearing bore profile can significantly reduce vibration amplitude.

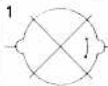
See table 1 for initial guidance.

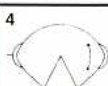
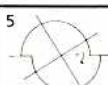
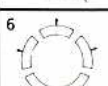
Table.1 Relative Performance Characteristics of Bearings for High Speed Shafts

Bearing Type	Resistance to Half Speed Whirl	Load Capacity	Stiffness	Damping	Acceptance of Rotating Load	Relative Cost	Advantages	Disadvantages	Applications	Usage
1  Plain Bore Two Axial Groove	●	●●●●	●●	●●	●●	○	Simple to install and line up machine	Prone to half speed whirl with light load and may require very low length/diameter ratio	All rotating machines, gearboxes and screw compressors	Wide
2  Plain Bore Circumferential Single Groove	●	●●●	●●	●●	●●●●	○	Best for rotating load. Simple to install and line up machine	Requires high oil supply pressure. Prone to half speed whirl with light load	Blowers, quill shaft steady bearings, some gearbox bearings	Moderate
3  Lemon Bore	●●	●●●●	●●●	●●●	●●	○ ○	Simple to install and line up machine	Low stiffness in horizontal direction	Large turbines and electrical machines. Pumps, gearboxes	Wide
4  Lemon Bore with bedded arc	●●	●●●●	●●●	●●●	●●	○ ○	Simple to install and line up machine	Low stiffness in horizontal direction	Large turbines and electrical machines.	Moderate
5  Offset Halves	●●●●	●●●●	●●●●	●●●●	●●	○ ○	High lubricant pumping action gives low operating temperatures	Not suitable for reverse rotation	Turbines, pumps, electric machines, compressors, gearboxes	Wide
6  Tilting Pad	●●●●	●●●	●●●	●●●	●●	○ ○ ○	Inherently most stable of all bearings. Adapts to changing load conditions	Pivots liable to fretting with rotating or dynamic load	All rotating machines, horizontal or vertical	Increasing
7  Four Lobe	●●	●●	●●●	●●●	●●	○ ○	Used mainly in small sizes as a thick wall flanged bearing sometimes with taper land thrust faces	Low load capacity due to four grooves and large lobe clearances	Small turbines, compressors, blowers pumps	Wide

Performance Rating ●●●● Very High ● Low Relative Cost ○ Low ○○ High



Machining stage of thick wall 4 lobe bearing for a 40MW gas turbine reduction gearbox.

## Rotor Dynamic Studies

To complete machine design studies Waukesha offer a full rotor dynamics service. See section 8

## Power Loss and Oil Flow

Waukesha Bearings design programs calculate operating characteristics on the basis of shaft size, load, oil viscosity and oil entry temperature

## Lubrication

### Confirming your selection

When main details or options for your machine are known Waukesha Bearings will help find the best bearing solution in terms of size and performance.

Photocopy the enquiry data sheet on page 21, complete for the number of parts you need to define and send to us for proposals.

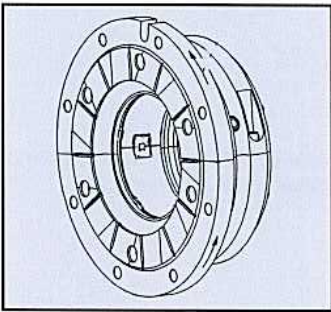

*Thickwall flanged bearing with taper land face*

### Ordering

When parts are ordered for new applications you will receive a contract drawing confirming sizes, interfaces and estimated performance data.

Please remember to confirm operating conditions and use part number codes from the size tables where possible.

NS type medium wall bearing with Waukesha Bearings standard jacking oil grooves. See section 8 for alternative single injection point design.

### Pressure Oil Supply

NS & KS bearings are designed for oil lubrication at an entry pressure from 0.5 to 2 bar.

Oil is supplied through 2 axial grooves, each 0.8 of the bearing length L and width 0.25 of the bearing bore D. This is suitable for approximately constant load direction.

Other forms of oil feed groove may be needed in special cases where bearing load rotates or has a large angular movement.

ISO VG 32, 46 and 68 oils are commonly used, with thicker oils for lower sliding speeds.

Performance data can also be supplied for synthetic lubricants.

### Hydrostatic Jacking

Where machines start or stop with bearings under load oil films cannot be generated and metal to metal contact can take place giving rise to high friction torque.

Hydrostatic jacking avoids this problem by injecting oil from a high pressure pump into special grooves

in the bearing load area. The shaft then floats on an oil film which separates shaft and bearing surfaces before the shaft rotates, so that wear is eliminated and friction torque becomes negligible.

Hydrostatic jacking is recommended whenever specific load on start up exceeds 1.4 MPa. The frequency of start-ups, rundown time, duration of any barring condition and available starting torque also influence the decision.

Waukesha Bearings standard jacking arrangement is by twin axial grooves shown in the photograph.

Designs are also supplied with a single injection point underneath the shaft dead centre. See photo in section 8.

### Drainage

Oil should be allowed to drain freely from both ends of the bearing. Ask us for advice where this is not possible.





## Performance Monitoring

Bearings can be an early indicator of machine condition in several ways and increasingly are fitted with thermocouples or resistance temperature detectors - RTDs. Provision for displacement and/or vibration probes can also be made.

Waukesha Bearings supply parts fully instrumented to our or your specification. We can advise about the best location and how temperature varies with distance from load line.

Where customers prefer to fit instrumentation at their own premises parts are premachined accordingly.

## Installation

### Shaft Diameter

The maximum shaft diameter is obtained by deducting the minimum running clearance from minimum bore size.

Recommended shaft tolerance grade is IT6. When locating thrust faces are used the collars on the shaft should have a diameter of not less than  $D_2$ , and a root radius of less than U - see tables 3, 4 and 5.

Shaft surface finish varies with size. A typical figure is 0.4 micrometre Ra at a diameter of 100 mm.

### Clearances

Typical values are shown in fig 1. Values for each application are supplied with operating data.

For thrust faces axial clearance can be obtained by making the distance between the shaft thrust faces to C8 limits; above 500mm this dimension should be:

+0.675mm  
nominal +0.550mm

Fig.1 Clearances: recommended minima against speed by shaft diameter

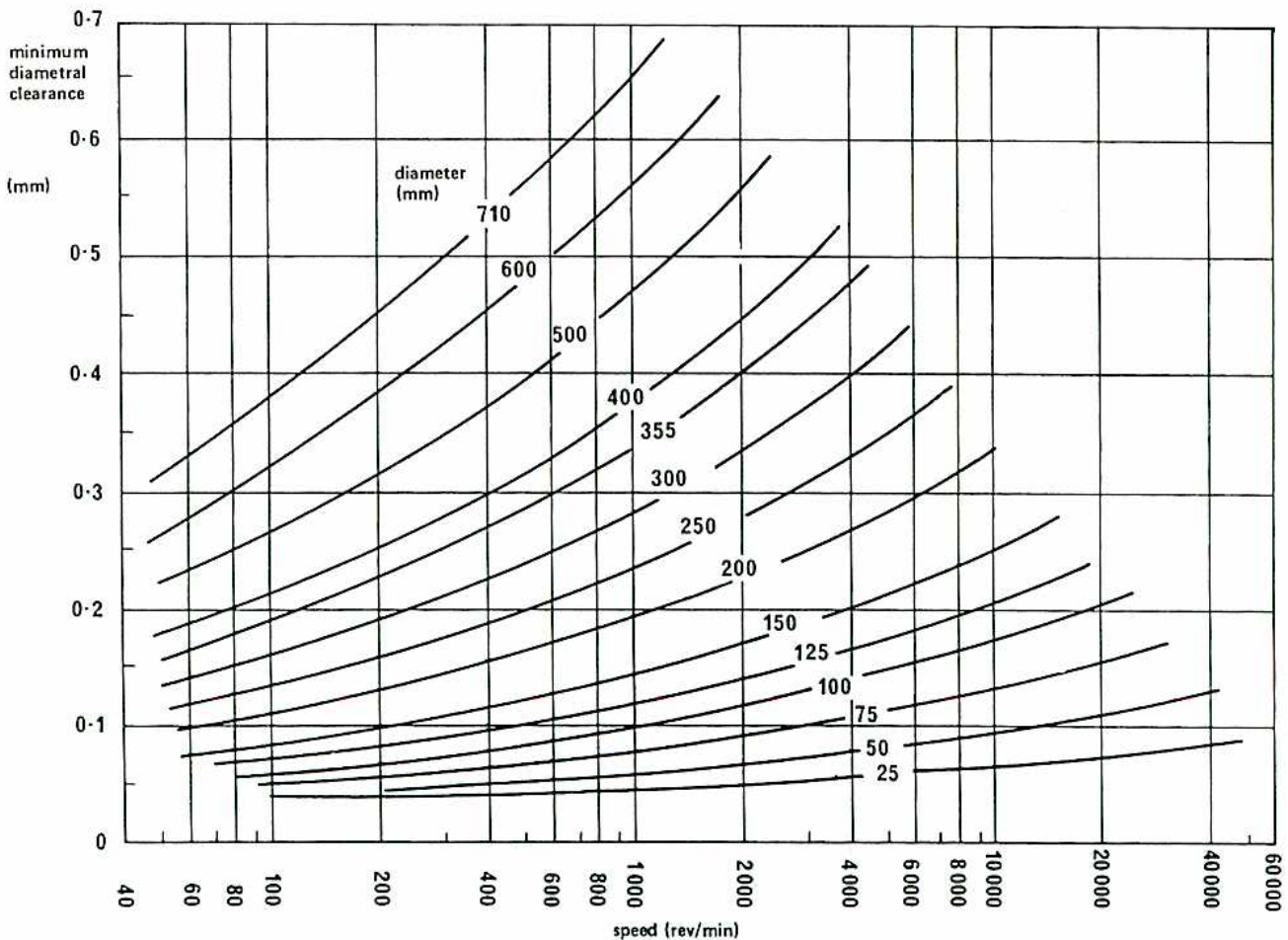



## Housing

Medium wall bearings are flexible and their assembled bore shape is achieved by interference fit in a housing of adequate stiffness with suitable joint face bolts. Waukesha Bearings can advise on recommended bolting force. Housings should be bored to H6 limits.

For KS thick wall bearings housings should be bored to H7 limits. The axial length over the housing end faces for parts with flanges should be to d10 limits and where there is a thrust face it should be to f7 limits - see tables 3, 4 and 5.

For NS medium wall bearings it may be necessary to machine oil supply grooves in the housing. We can advise on design where separate thrust washers are fitted.

## Bearing Free Spread

To ensure uniform housing contact NS and KS bearings are supplied with positive free spread. Bearing diameter at the joint face is thus greater when measured in the free state than when held in its housing.

The amount of free spread varies with shaft diameter and wall thickness.

## Assembly

NS bearing halves are provided with button stop recesses for location as shown in table 2 and figure 2.

KS bearings are supplied with provision for one location dowel on the top centre line. Any practical disadvantage with this arrangement can also be overcome by fitting button stops.

TABLE 2

All dimensions in mm

Size	Recess Diameter A	Recess Depth		Position D	Tapped Hole	
		HSG B	BRG C		Size E	Depth F
12	12.13	5.05	5.64	3.78	M4	8
	11.87	4.97	5.56	3.37		
16	16.13	5.60	6.18	4.48	M5	10
	15.87	5.52	6.10	4.07		
20	20.15	6.20	6.93	5.89	M6	12
	19.85	6.10	6.83	5.48		
25	25.15	7.92	8.77	7.39	M8	16
	24.85	7.82	8.67	6.98		
35	35.20	9.57	10.42	10.39	M10	20
	34.80	9.47	10.32	9.88		
50	50.23	13.24	14.13	14.89	M12	24
	49.77	13.11	14.00	14.38		
70	70.25	16.96	17.98	20.51	M16	32
	69.75	16.83	17.85	20.00		

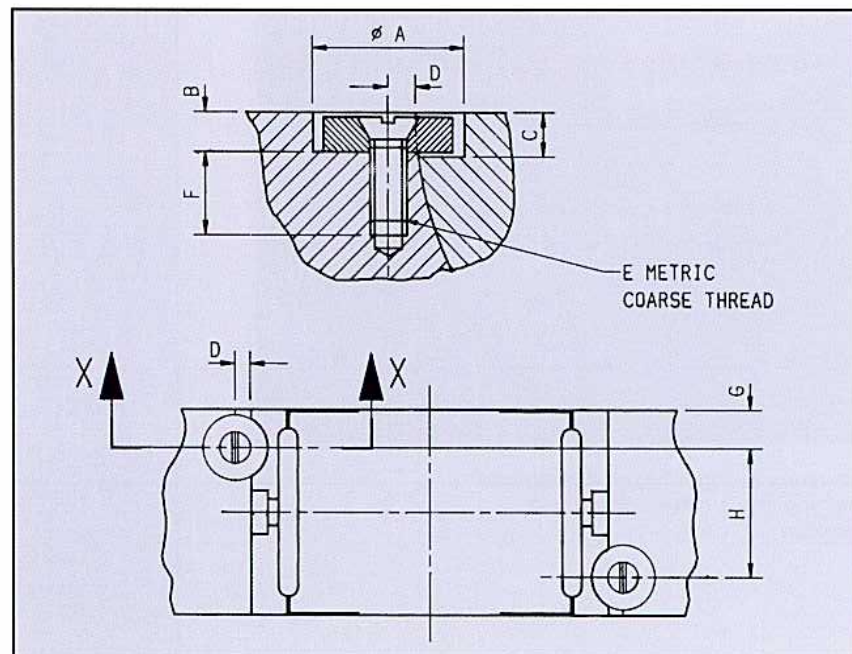

Fig 2 Details of button stop location

# Installation

Continued

Bearings should be located so that the joint line is at  $90^\circ$  to the load line. Deviations of up to  $\pm 30^\circ$  from this angle do not seriously reduce load capacity.

It may be necessary to rotate the bearing within the housing, typically for gearboxes. In this case a special form of button stop recess can be used for location as shown in fig 3 or a dowel locating in a recess cut in the lower half bearing housing may be used, as illustrated in fig 4.

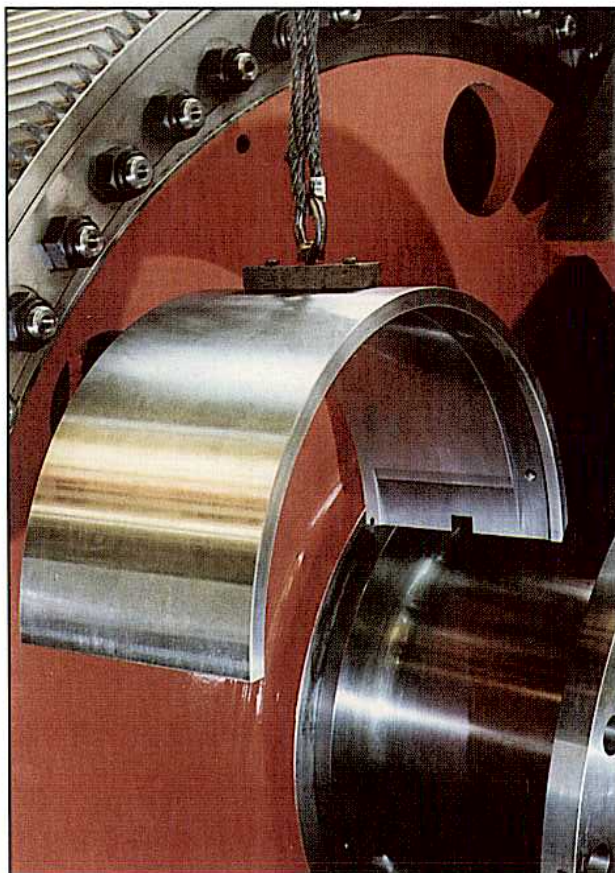

Lowering a large NS type medium wall bearing into a marine propulsion gearbox.

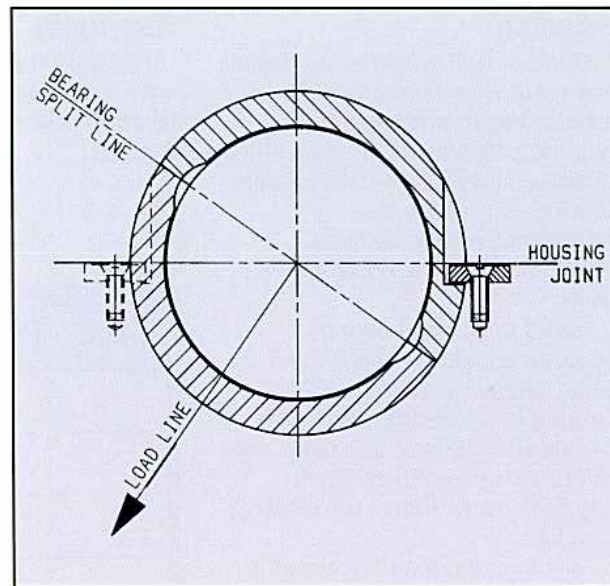
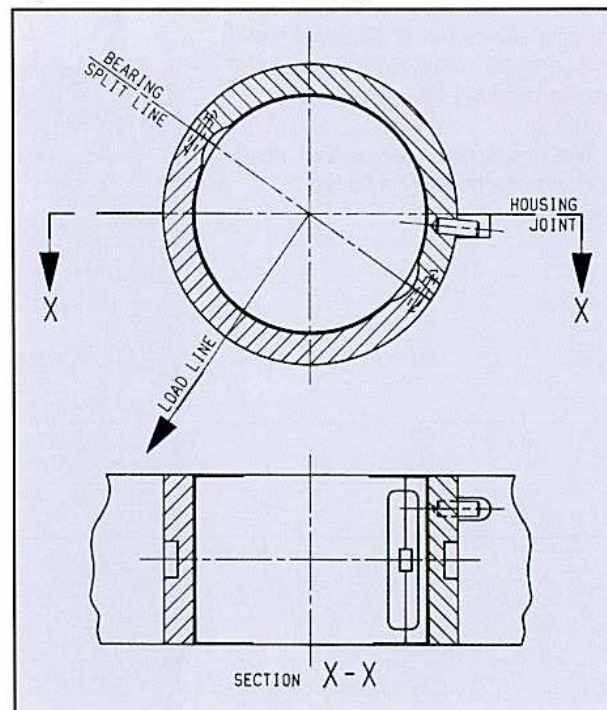

Fig.3 Button stop location with rotated joint face

Fig.4 Dowel location with rotated joint face





## Higher Performance Materials

Standard lining material is high Sn whitemetal GM130S to ISO SnSb8Cu4, ASTM B23-00 Grade 2 and BS3332/A, an excellent and widely used alloy.

Where you need to extend performance limits please consult us about the materials below:

Material Code	Material	Size Limit	Benefits
GM155	Pb based whitemetal (Babbitt)	-	Resist thermal cycling.
AS45	40% Sn Al	400mm shaft NS range only	Higher operating temperatures and fatigue strength.
LB20	Cu Pb Sn5	400mm shaft	Higher operating temperatures and fatigue strength.
RPB 25P	Polymer	400mm shaft NS range only	Withstands high ambient temperatures. Good marginal lubrication properties.

## Special Designs and Related Products

### Large and Complex Parts

We regularly design and make parts up to 1500mm outside diameter and 5 tonne weight.

### Backing Materials

Cast iron, cast steel and bronze are used for various duties and we specialize in lining these with white metal.

### Reverse Engineering

To extend life, uprate equipment, or reduce maintenance, bearing design of machines in service may need improvement. Our experience could solve your problem, even where drawings no longer exist.

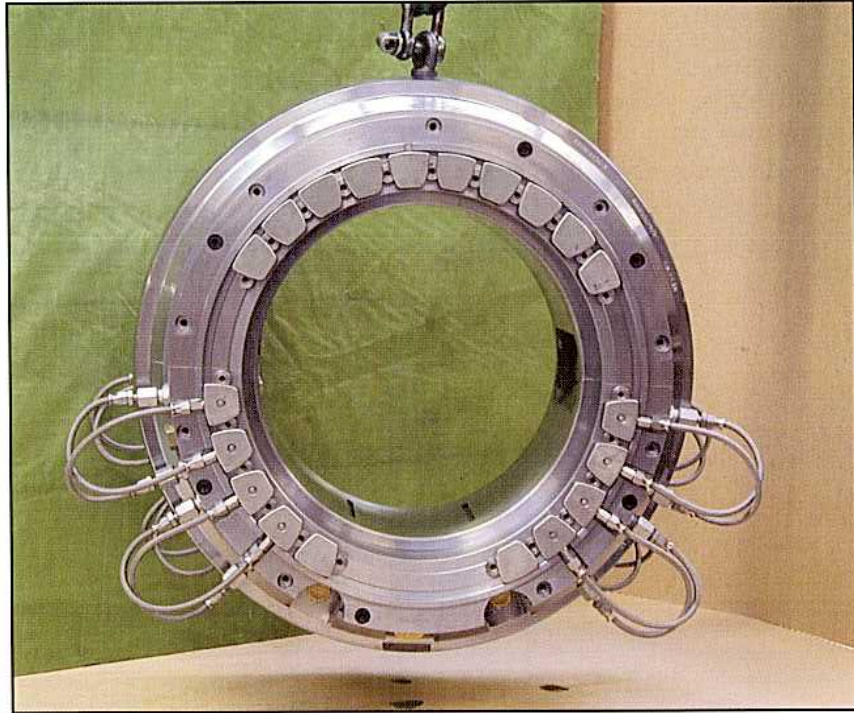

*10" lemon bore journal bearing, in combination with hydrostatically jacked thrust pads on both faces.*



*1500mm journal bearing with taper land thrust face for 2.5MW marine alternator drive.*

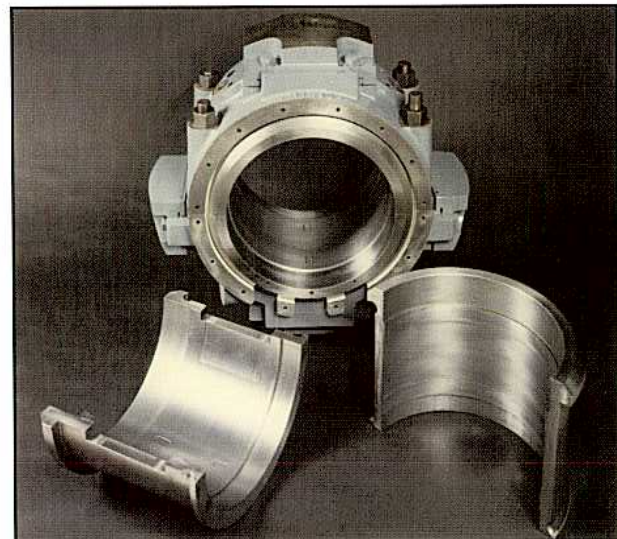

*550MW steam turbine journal bearing retrofitted with medium wall shell to Waukesha Bearings design. Note central jacking oil exits designed to suit existing system.*



## Rotor Dynamics Studies

Using our own computer design programs and Waukesha Bearings generated bearing coefficients we carry out full rotating machine studies, including response to unbalance and stability, and undamped natural frequency.

This calls for an exchange of data in some detail and the effect of design features on machine stability can often be examined live on our computer screens.

## Tilting Pad Thrust Bearings

See DHB 5A for a wide, adaptable and compact range of high capacity bearings.

If you need equalised thrust rings to meet API or other standards see our CQ range.

## Tilting Pad Journal Bearings

The most inherently stable form of journal bearing, and especially beneficial at high shaft speed and light loads. See DHB 10.

## Pressure Fed and Self-Contained Assemblies

Compact pressure fed bearing cartridges are supplied with and without thrust capacity and including parts in this handbook.

Self contained vertical bearing assemblies are also available. See DHB 13.

## Repairs

Waukesha Bearings can repair large thickwall or special types of whitmetal bearing. This is often advantageous when rapid turnaround is required.



*Rotor dynamics study in progress showing mass unbalance distribution and output stations for synchronous response analysis.*

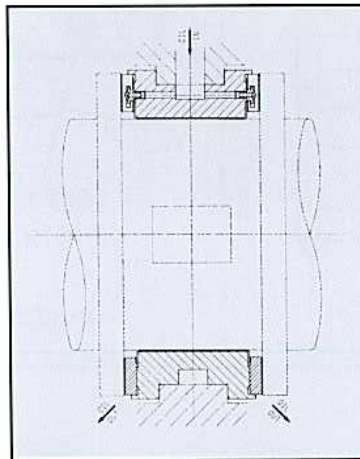

*300mm gearbox offset halves journal bearing fitted with Directed Lubrication tilting pad thrust faces.*

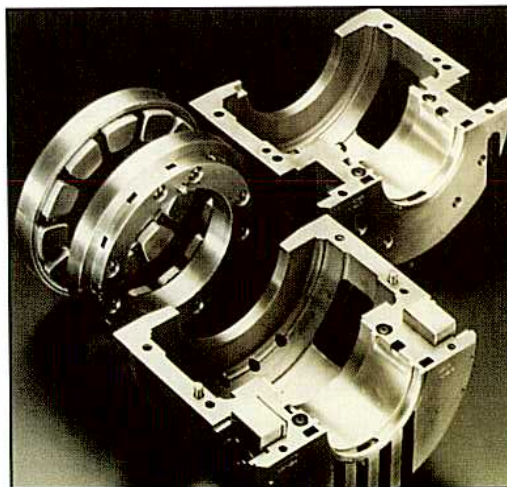

*Steam turbine thrust and journal bearing cartridge. Note NS journal bearing located with button stops.*

**PLAIN BEARING IN HALVES (KSA)**

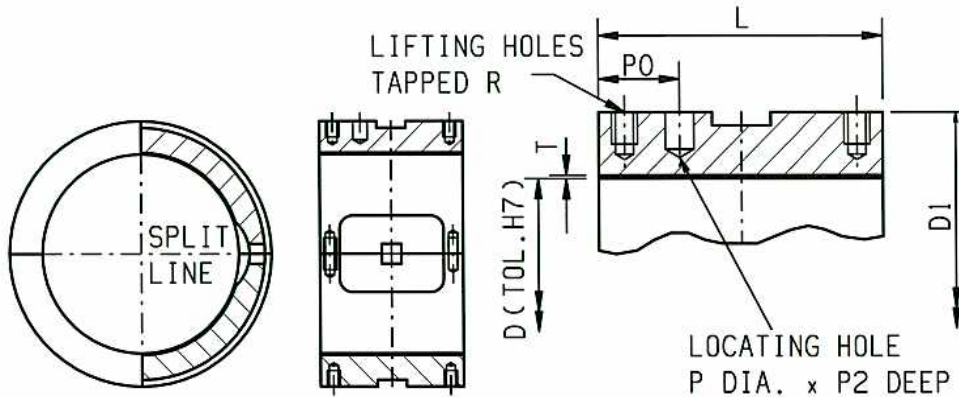

APPROX. WEIGHT (2 HALVES) = 1 kg

**PLAIN BEARING IN HALVES WITH FLANGES (KSB)**

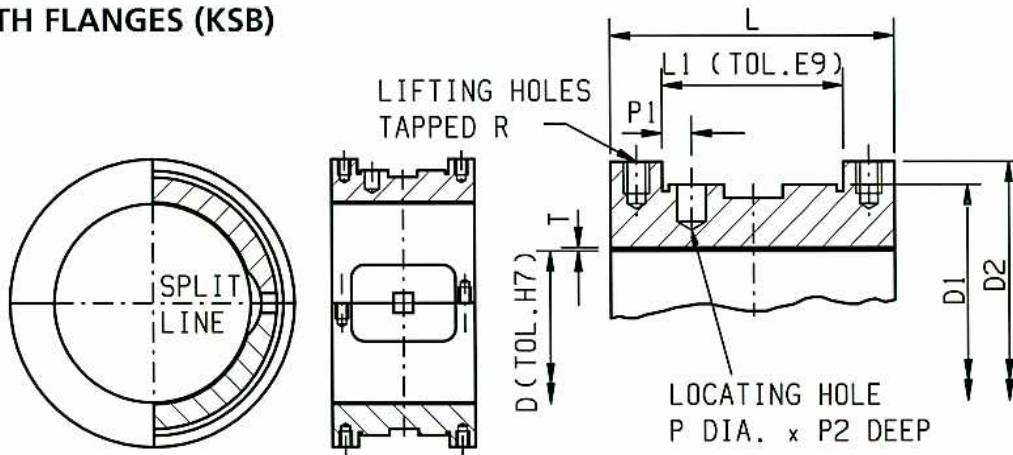

APPROX. WEIGHT (2 HALVES) = 1 kg

**PLAIN BEARING IN HALVES WITH FLANGES AND LOCATING FACES (KSC)**

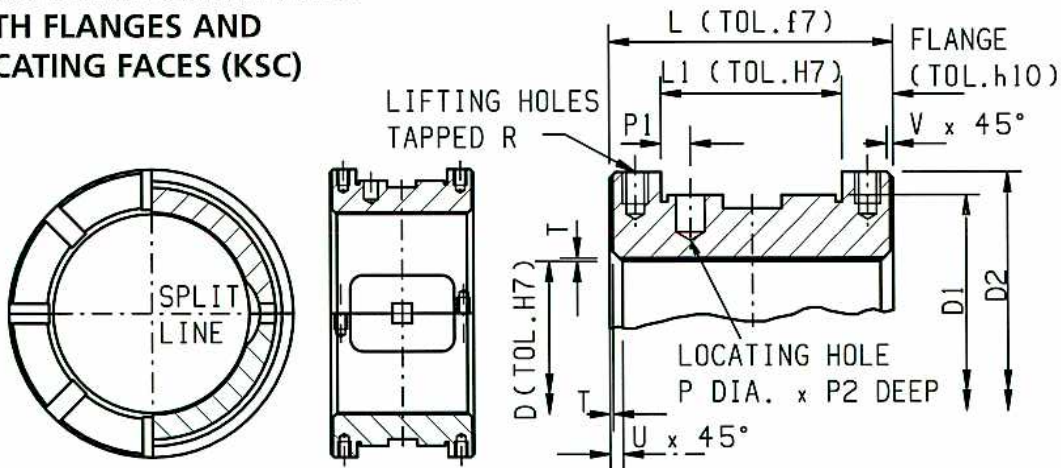

APPROX. WEIGHT (2 HALVES) = 1 kg



Size Tables

Table 3 Thick Wall Bearings L/D = 0.5

Size Plain bearing in Halves (KSA)	Size Plain bearing in Halves with Flanges (KSB)	Size Plain bearing in Halves with Flanges & Locating Faces (KSC)	D Bore	D <sub>1</sub>		D <sub>2</sub>	I	L	L <sub>1</sub>	P	P <sub>0</sub>	P <sub>1</sub>	P <sub>2</sub>	R	T	U	V
					Tol												
050 KSA 025	050 KSB 025	050 KSC 025	50	65		70	0.31	25	17	4	6	4	3		1	2.5	0.75
052 KSA 025	052 KSB 025	052 KSC 025	52	65		70	0.28	25	17	4	6	4	3		1	2.5	0.75
055 KSA 025	055 KSB 025	055 KSC 025	55	70	m6	75	0.34	25	17	4	6	4	3		1	2.5	0.75
056 KSA 030	056 KSB 030	056 KSC 030	56	70		75	0.39	30	20	4	7	5	3		1	2.5	0.75
058 KSA 030	058 KSB 030	058 KSC 030	58	75		80	0.48	30	20	4	7	5	3		1	2.5	0.75
060 KSA 030	060 KSB 030	060 KSC 030	60	80		85	0.58	30	20	4	7	5	3		1	2.5	0.75
063 KSA 030	063 KSB 030	063 KSC 030	63	80		85	0.51	30	20	4	7	5	3		1	2.5	0.75
065 KSA 030	065 KSB 030	065 KSC 030	65	85	m6	90	0.62	30	20	4	7	5	3		1	2.5	0.75
068 KSA 035	068 KSB 035	068 KSC 035	68	85		90	0.63	35	25	4	8	4	3		1	2.5	0.75
070 KSA 035	070 KSB 035	070 KSC 035	70	90		95	0.76	35	25	4	8	4	3		1	2.5	0.75
072 KSA 035	072 KSB 035	072 KSC 035	72	90		95	0.70	35	25	4	8	4	3		1	2.5	0.75
075 KSA 035	075 KSB 035	075 KSC 035	75	95		101	0.79	35	25	4	8	4	3		1	2.5	0.75
080 KSA 040	080 KSB 040	080 KSC 040	80	105	m6	111	1.2	40	30	4	10	5	3		1	2.5	0.75
085 KSA 040	085 KSB 040	085 KSC 040	85	110		116	1.3	40	30	5	10	5	4		1	3	0.75
090 KSA 045	090 KSB 045	090 KSC 045	90	115		121	1.5	45	30	5	10	5	4		1	3	0.75
095 KSA 045	095 KSB 045	095 KSC 045	95	120		126	1.6	45	30	5	10	5	4		1	3	0.75
100 KSA 050	100 KSB 050	100 KSC 050	100	130	m6	136	2.3	50	35	6	13	6	5		1	3	0.75
105 KSA 050	105 KSB 050	105 KSC 050	105	135	k6	142	2.4	50	35	6	13	6	5		1.5	3	1
110 KSA 055	110 KSB 055	110 KSC 055	110	140		147	2.6	55	40	6	13	7	5		1.5	3	1
120 KSA 060	120 KSB 060	120 KSC 060	120	155		162	3.7	60	40	7	13	7	6		1.5	3	1
125 KSA 060	125 KSB 060	125 KSC 060	125	160		168	3.9	60	40	7	13	7	6		1.5	4	1
130 KSA 065	130 KSB 065	130 KSC 065	130	170		178	5.1	65	45	7	16	8	6		1.5	4	1
140 KSA 070	140 KSB 070	140 KSC 070	140	180	k6	188	5.8	70	50	7	16	8	6		1.5	4	1
150 KSA 075	150 KSB 075	150 KSC 075	150	195		203	7.5	75	50	9	20	8	8		1.5	4	1
160 KSA 080	160 KSB 080	160 KSC 080	160	205		213	8.4	80	55	9	20	10	8		1.5	4	1
170 KSA 085	170 KSB 085	170 KSC 085	170	220		228	10.4	85	60	9	20	10	8		1.5	5	1
180 KSA 090	180 KSB 090	180 KSC 090	180	230		238	11.6	90	65	9	20	12	8		1.5	5	1
190 KSA 095	190 KSB 095	190 KSC 095	190	245	k6	255	14.6	95	65	11	25	12	10		1.5	5	1
200 KSA 100	200 KSB 100	200 KSC 100	200	260		270	17.7	100	70	11	25	12	10		1.5	5	1
210 KSA 105	210 KSB 105	210 KSC 105	210	270		280	19.1	105	75	11	25	12	10		1.5	8	1
225 KSA 110	225 KSB 110	225 KSC 110	225	290		300	23.2	110	75	11	30	12	10	M8	1.5	8	1
235 KSA 115	235 KSB 115	235 KSC 115	235	305		315	27.0	115	80	11	30	12	10	M8	1.5	8	1
250 KSA 125	250 KSB 125	250 KSC 125	250	325	k6	337	34.3	125	85	13	35	16	15	M8	1.5	10	1
265 KSA 130	265 KSB 130	265 KSC 130	265	345	j <sub>s</sub> 6	357	40.3	130	90	13	35	16	15	M8	2	10	1.5
280 KSA 140	280 KSB 140	280 KSC 140	280	360		372	45.5	140	100	13	40	20	15	M8	2	10	1.5
300 KSA 150	300 KSB 150	300 KSC 150	300	390		403	58.8	150	105	15.25	40	20	18	M10	2	10	1.5
315 KSA 155	315 KSB 155	315 KSC 155	315	410		425	67.3	155	110	15.25	40	20	18	M10	2	13	1.5
335 KSA 165	335 KSB 165	335 KSC 165	335	435	j <sub>s</sub> 6	451	80.6	165	115	15.25	50	20	18	M10	2	13	1.5
355 KSA 175	355 KSB 175	355 KSC 175	355	460		476	95.3	175	120	15.25	50	25	18	M10	2	13	1.5
375 KSA 185	375 KSB 185	375 KSC 185	375	485		501	111	185	130	17.5	50	25	20	M12	2	13	1.5
400 KSA 200	400 KSB 200	400 KSC 200	400	515		531	134	200	140	17.5	60	25	20	M12	2	13	1.5
425 KSA 210	425 KSB 210	425 KSC 210	425	550		566	161	210	145	22	60	25	25	M12	2.5	16	1.5
450 KSA 225	450 KSB 225	450 KSC 225	450	580	j <sub>s</sub> 6	596	190	225	155	22	70	30	25	M16	2.5	16	1.5
475 KSA 235	475 KSB 235	475 KSC 235	475	610		628	217	235	165	27	70	30	30	M16	2.5	16	2
500 KSA 250	500 KSB 250	500 KSC 250	500	645		663	262	250	175	27	70	35	30	M16	2.5	16	2
530 KSA 265	530 KSB 265	530 KSC 265	530	685		703	314	265	185	27	70	35	30	M20	3	20	2
560 KSA 280	560 KSB 280	560 KSC 280	560	720		738	360	280	195	32	80	40	30	M20	3	20	2
600 KSA 300	600 KSB 300	600 KSC 300	600	770	j <sub>s</sub> 6	790	440	300	210	32	80	40	30	M20	3	20	2
630 KSA 315	630 KSB 315	630 KSC 315	630	810		830	511	315	220	42	90	40	40	M20	3.5	24	2
670 KSA 335	670 KSB 335	670 KSC 335	670	860		880	607	335	235	42	90	45	40	M24	3.5	24	2
710 KSA 355	710 KSB 355	710 KSC 355	710	910	j <sub>s</sub> 6	930	718	355	250	42	100	50	40	M24	3.5	28	2

Dimensions in mm



# Size tables

## Table 4 Thick Wall Bearings L/D = 0.75

Size Plain bearing in Halves (KSA)	Size Plain bearing in Halves with Flanges (KSB)	Size Plain bearing in Halves with Flanges & Locating Faces (KSC)	D Bore	D <sub>1</sub>		D <sub>2</sub>	I	L	L <sub>1</sub>	P	P <sub>0</sub>	P <sub>1</sub>	P <sub>2</sub>	R	T	U	V
					Tol												
050 KSA 035	050 KSB 035	050 KSC 035	50	65	m6	70	0.42	35	25	4	10	5	3		1	4	0.75
052 KSA 040	052 KSB 040	052 KSC 040	52	65		70	0.43	40	30	4	10	5	3		1	4	0.75
055 KSA 040	055 KSB 040	055 KSC 040	55	70		75	0.52	40	30	4	10	6	3		1	4	0.75
056 KSA 040	056 KSB 040	056 KSC 040	56	70		75	0.50	40	30	4	10	6	3		1	4	0.75
058 KSA 045	058 KSB 045	058 KSC 045	58	75		80	0.72	45	30	4	10	6	3		1	4	0.75
060 KSA 045	060 KSB 045	060 KSC 045	60	80	m6	85	0.86	45	30	4	10	6	4		1	4	0.75
063 KSA 045	063 KSB 045	063 KSC 045	63	80		85	0.76	45	30	4	10	6	4		1	4	0.75
065 KSA 050	065 KSB 050	065 KSC 050	65	85		90	1.00	50	35	5	12	6	4		1	4	0.75
068 KSA 050	068 KSB 050	068 KSC 050	68	85		90	0.90	50	35	5	12	6	4		1	4	0.75
070 KSA 050	070 KSB 050	070 KSC 050	70	90		95	1.1	50	35	5	12	6	4		1	4	0.75
072 KSA 050	072 KSB 050	072 KSC 050	72	90	m6	95	0.98	50	35	5	12	6.5	4		1	4	0.75
075 KSA 055	075 KSB 055	075 KSC 055	75	95		101	1.2	55	40	5	12	6.5	4		1	4	0.75
080 KSA 060	080 KSB 060	080 KSC 060	80	105		111	1.8	60	40	5	15	6.5	5		1	4	0.75
085 KSA 065	085 KSB 065	085 KSC 065	85	110		116	2.1	65	45	6	15	8	5		1	5	0.75
090 KSA 065	090 KSB 065	090 KSC 065	90	115		121	2.2	65	45	6	15	8	5		1	5	0.75
095 KSA 070	095 KSB 070	095 KSC 070	95	120	m6	126	2.5	70	50	6	15	8	5		1	5	0.75
100 KSA 075	100 KSB 075	100 KSC 075	100	130		136	3.4	75	50	7	20	9	6		1	5	0.75
105 KSA 080	105 KSB 080	105 KSC 080	105	135		142	3.8	80	55	7	20	9	6		1.5	5	1
110 KSA 080	110 KSB 080	110 KSC 080	110	140		147	3.9	80	55	7	20	9	6		1.5	5	1
120 KSA 090	120 KSB 090	120 KSC 090	120	155		162	5.6	90	60	9	20	10	8		1.5	5	1
125 KSA 095	125 KSB 095	125 KSC 095	125	160	k6	168	6.2	95	65	9	20	12	8		1.5	6	1
130 KSA 100	130 KSB 100	130 KSC 100	130	170		178	7.8	100	70	9	25	12	8		1.5	6	1
140 KSA 105	140 KSB 105	140 KSC 105	140	180		188	8.7	105	75	9	25	14	8		1.5	6	1
150 KSA 115	150 KSB 115	150 KSC 115	150	195		203	11.6	115	80	11	32	15	10	M8	1.5	6	1
160 KSA 120	160 KSB 120	160 KSC 120	160	205		213	12.5	120	85	11	32	15	10	M8	1.5	6	1
170 KSA 130	170 KSB 130	170 KSC 130	170	220	k6	228	16.2	130	90	11	32	15	10	M8	1.5	8	1
180 KSA 135	180 KSB 135	180 KSC 135	180	230		238	17.7	135	95	11	32	18	10	M8	1.5	8	1
190 KSA 145	190 KSB 145	190 KSC 145	190	245		255	22.5	145	100	13	40	18	15	M8	1.5	8	1
200 KSA 150	200 KSB 150	200 KSC 150	200	260		270	26.7	150	105	13	40	20	15	M8	1.5	8	1
210 KSA 160	210 KSB 160	210 KSC 160	210	270		280	29.5	160	110	13	40	20	15	M10	1.5	12	1
225 KSA 170	225 KSB 170	225 KSC 170	225	290	k6	300	36.0	170	120	13	40	20	15	M10	1.5	12	1
235 KSA 175	235 KSB 175	235 KSC 175	235	305		315	42.0	175	120	13	40	20	15	M10	1.5	12	1
250 KSA 190	250 KSB 190	250 KSC 190	250	325		337	52.5	190	130	15.25	50	25	18	M10	1.5	15	1
265 KSA 200	265 KSB 200	265 KSC 200	265	345		357	62.3	200	140	15.25	50	25	18	M10	2	15	1.5
280 KSA 210	280 KSB 210	280 KSC 210	280	360		372	68.9	210	145	15.25	60	28	20	M10	2	15	1.5
300 KSA 225	300 KSB 225	300 KSC 225	300	390	j <sub>5</sub> 6	403	88.9	225	155	17.5	60	30	20	M12	2	15	1.5
315 KSA 235	315 KSB 235	315 KSC 235	315	410		425	103	235	165	17.5	60	30	20	M12	2	20	1.5
335 KSA 250	335 KSB 250	335 KSC 250	335	435		451	123	250	175	17.5	70	35	20	M12	2	20	1.5
355 KSA 265	355 KSB 265	355 KSC 265	355	460		476	145	265	185	17.5	70	35	20	M16	2	20	1.5
375 KSA 280	375 KSB 280	375 KSC 280	375	485		501	169	280	195	22	70	40	25	M16	2	20	1.5
400 KSA 300	400 KSB 300	400 KSC 300	400	515	j <sub>5</sub> 6	531	201	300	210	22	85	40	25	M16	2	20	1.5
425 KSA 320	425 KSB 320	425 KSC 320	425	550		566	246	320	220	27	85	50	30	M20	2.5	25	1.5
450 KSA 340	450 KSB 340	450 KSC 340	450	580		596	287	340	235	27	110	60	30	M20	2.5	25	1.5
475 KSA 355	475 KSB 355	475 KSC 355	475	610		628	330	355	245	32	110	60	30	M20	2.5	25	2
500 KSA 375	500 KSB 375	500 KSC 375	500	645		663	394	375	260	32	110	60	30	M20	2.5	25	2
530 KSA 400	530 KSB 400	530 KSC 400	530	685	j <sub>5</sub> 6	703	474	400	280	32	110	60	30	M24	3	30	2
560 KSA 420	560 KSB 420	560 KSC 420	560	720		738	539	420	295	42	120	60	40	M24	3	30	2
600 KSA 450	600 KSB 450	600 KSC 450	600	770		790	660	450	315	42	120	60	40	M24	3	30	2
630 KSA 470	630 KSB 470	630 KSC 470	630	810		830	764	470	330	52	150	70	50	M30	3.5	35	2
670 KSA 500	670 KSB 500	670 KSC 500	670	860		880	908	500	350	52	150	70	50	M30	3.5	35	2
710 KSA 530	710 KSB 530	710 KSC 530	710	910	j <sub>5</sub> 6	930	1074	530	370	52	150	70	50	M30	3.5	40	2

Dimensions in mm



# Size Tables

## Table 5 Thick Wall Bearings L/D = 1.0

Size Plain bearing in Halves (KSA)	Size Plain bearing in Halves with Flanges (KSB)	Size Plain bearing in Halves with Flanges & Locating Faces (KSC)	D Bore	D <sub>1</sub>		D <sub>2</sub>	I	L	L <sub>1</sub>	P	P <sub>0</sub>	P <sub>1</sub>	P <sub>2</sub>	R	T	U	V
					Tol												
050 KSA 050	050 KSB 050	050 KSC 050	50	65	m6	70	0.62	50	35	4	10	5	3		1	4	0.75
052 KSA 052	052 KSB 052	052 KSC 052	52	65		70	0.59	52	35	4	10	5	3		1	4	0.75
055 KSA 055	055 KSB 055	055 KSC 055	55	70		75	0.74	55	40	4	10	6	3		1	4	0.75
056 KSA 056	056 KSB 056	056 KSC 056	56	70		75	0.72	56	40	4	10	6	3		1	4	0.75
058 KSA 058	058 KSB 058	058 KSC 058	58	75		80	0.93	58	40	4	10	6	3		1	4	0.75
060 KSA 060	060 KSB 060	060 KSC 060	60	80	m6	85	1.2	60	40	4	10	6	4		1	4	0.75
063 KSA 063	063 KSB 063	063 KSC 063	63	80		85	1.1	63	40	4	10	6	4		1	4	0.75
065 KSA 065	065 KSB 065	065 KSC 065	65	85		90	1.3	65	45	5	12	6	4		1	4	0.75
068 KSA 068	068 KSB 068	068 KSC 068	68	85		90	1.2	68	50	5	12	6	4		1	4	0.75
070 KSA 070	070 KSB 070	070 KSC 070	70	90		95	1.5	70	50	5	12	6	4		1	4	0.75
072 KSA 072	072 KSB 072	072 KSC 072	72	90	m6	95	1.5	72	50	5	12	6.5	4		1	4	0.75
075 KSA 075	075 KSB 075	075 KSC 075	75	95		101	1.7	75	50	5	12	6.5	4		1	4	0.75
080 KSA 080	080 KSB 080	080 KSC 080	80	105		111	2.5	80	55	5	15	6.5	5		1	4	0.75
085 KSA 085	085 KSB 085	085 KSC 085	85	110		116	2.8	85	60	6	15	8	5		1	5	0.75
090 KSA 090	090 KSB 090	090 KSC 090	90	115		121	3.1	90	65	6	15	8	5		1	5	0.75
095 KSA 095	095 KSB 095	095 KSC 095	95	120	m6	126	3.4	95	65	6	15	8	5		1	5	0.75
100 KSA 100	100 KSB 100	100 KSC 100	100	130		136	4.6	100	70	7	20	9	6		1	5	0.75
105 KSA 105	105 KSB 105	105 KSC 105	105	135		142	5.1	105	75	7	20	9	6		1.5	5	1
110 KSA 110	110 KSB 110	110 KSC 110	110	140		147	5.4	110	75	7	20	9	6		1.5	5	1
120 KSA 120	120 KSB 120	120 KSC 120	120	155		162	7.5	120	85	9	20	10	8		1.5	5	1
125 KSA 125	125 KSB 125	125 KSC 125	125	160	k6	168	8.2	125	90	9	20	12	8		1.5	6	1
130 KSA 130	130 KSB 130	130 KSC 130	130	170		178	10.3	130	90	9	25	12	8		1.5	6	1
140 KSA 140	140 KSB 140	140 KSC 140	140	180		188	11.8	140	100	9	25	14	8		1.5	6	1
150 KSA 150	150 KSB 150	150 KSC 150	150	195		203	15.2	150	105	11	32	15	10	M8	1.5	6	1
160 KSA 160	160 KSB 160	160 KSC 160	160	205		213	17.0	160	110	11	32	15	10	M8	1.5	6	1
170 KSA 170	170 KSB 170	170 KSC 170	170	220	k6	228	21.4	170	120	11	32	15	10	M8	1.5	8	1
180 KSA 180	180 KSB 180	180 KSC 180	180	230		238	23.9	180	125	11	32	18	10	M8	1.5	8	1
190 KSA 190	190 KSB 190	190 KSC 190	190	245		255	29.6	190	135	13	40	18	15	M8	1.5	8	1
200 KSA 200	200 KSB 200	200 KSC 200	200	260		270	35.9	200	140	13	40	20	15	M8	1.5	8	1
210 KSA 210	210 KSB 210	210 KSC 210	210	270		280	39.1	210	145	13	40	20	15	M10	1.5	12	1
225 KSA 225	225 KSB 225	225 KSC 225	225	290	k6	300	48.2	225	160	13	40	20	15	M10	1.5	12	1
235 KSA 235	235 KSB 235	235 KSC 235	235	305		315	55.1	235	165	13	40	20	15	M10	1.5	12	1
250 KSA 250	250 KSB 250	250 KSC 250	250	325		337	69.5	250	175	15.25	50	25	18	M10	1.5	15	1
265 KSA 265	265 KSB 265	265 KSC 265	265	345		357	88.1	265	185	15.25	50	25	18	M10	2	15	1.5
280 KSA 280	280 KSB 280	280 KSC 280	280	360		372	92.5	280	195	15.25	60	28	20	M10	2	15	1.5
300 KSA 300	300 KSB 300	300 KSC 300	300	390	j <sub>5</sub> 6	403	119	300	210	17.5	60	30	20	M12	2	15	1.5
315 KSA 315	315 KSB 315	315 KSC 315	315	410		425	139	315	220	17.5	60	30	20	M12	2	20	1.5
335 KSA 335	335 KSB 335	335 KSC 335	335	435		451	166	335	235	17.5	70	35	20	M12	2	20	1.5
355 KSA 355	355 KSB 355	355 KSC 355	355	460		476	195	355	250	17.5	70	35	20	M16	2	20	1.5
375 KSA 375	375 KSB 375	375 KSC 375	375	485		501	228	375	260	22	70	40	25	M16	2	20	1.5
400 KSA 400	400 KSB 400	400 KSC 400	400	515	j <sub>5</sub> 6	531	253	400	280	22	85	40	25	M16	2	20	1.5
425 KSA 425	425 KSB 425	425 KSC 425	425	550		566	328	425	300	27	85	50	30	M20	2.5	25	1.5
450 KSA 450	450 KSB 450	450 KSC 450	450	580		596	382	450	320	27	110	60	30	M20	2.5	25	1.5
475 KSA 475	475 KSB 475	475 KSC 475	475	610		628	444	475	330	32	110	60	30	M20	2.5	25	2
500 KSA 500	500 KSB 500	500 KSC 500	500	645		663	528	500	350	32	110	60	30	M20	2.5	25	2
530 KSA 530	530 KSB 530	530 KSC 530	530	685	j <sub>5</sub> 6	703	632	530	370	32	110	60	30	M24	3	30	2
560 KSA 560	560 KSB 560	560 KSC 560	560	720		738	724	560	390	42	120	60	40	M24	3	30	2
600 KSA 600	600 KSB 600	600 KSC 600	600	770		790	886	600	420	42	120	60	40	M24	3	30	2
630 KSA 630	630 KSB 630	630 KSC 630	630	810		830	1031	630	440	52	150	70	50	M30	3.5	35	2
670 KSA 670	670 KSB 670	670 KSC 670	670	860		880	1226	670	470	52	150	70	50	M30	3.5	35	2
710 KSA 710	710 KSB 710	710 KSC 710	710	910	j <sub>5</sub> 6	930	1447	710	500	52	150	70	50	M30	3.5	40	2

Dimensions in mm

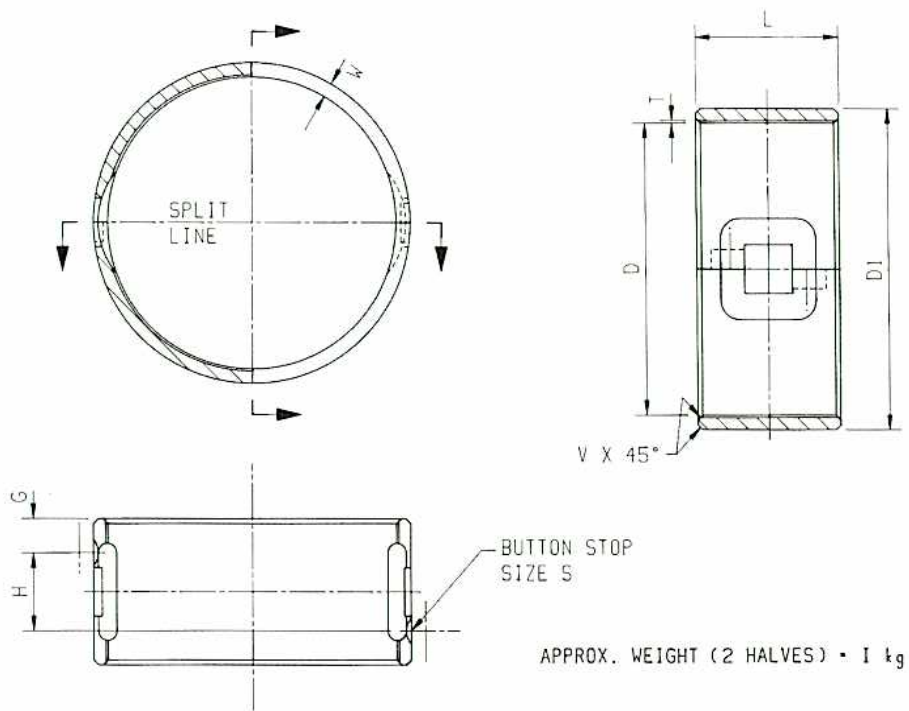

**Table 6 Medium Wall Bearings L/D = 0.5**

Size	D	D <sub>1</sub>	G	H	I	L	S	T	V	W
100 NSA 050	100.000 100.056	110	7	35.75 36.25	0.65	50	12	1	1	5
110 NSA 055	110.000 110.056	120	9.5	35.75 36.25	0.78	55	12	1	1	5
125 NSA 060	125.000 125.059	135	10	39.75 40.25	0.96	60	12	1	1	5
140 NSA 070	140.000 140.059	150	15	39.75 40.25	1.3	70	12	1	1	5
160 NSA 080	160.000 160.059	170	15	49.75 50.25	1.6	80	12	1	1	5
180 NSA 090	180.000 180.063	192	20	49.75 50.25	2.5	90	16	1	1	6
200 NSA 100	200.000 200.067	212	20	59.75 60.25	3.0	100	16	1	1	6
225 NSA 110	225.000 225.067	241	25	59.75 60.25	5.1	110	16	1	1	8
250 NSA 125	250.000 250.070	266	30	64.75 65.25	6.4	125	16	1	1	8
280 NSA 140	280.000 280.070	296	35	69.75 70.25	7.9	140	16	1	1.5	8
315 NSA 155	315.000 315.086	335	35	84.6 85.4	12.4	155	20	1.5	1.5	10
355 NSA 175	355.000 355.086	375	40	94.6 95.4	19.5	175	20	1.5	1.5	10
400 NSA 200	400.000 400.090	425	45	109.6 110.4	25.4	200	25	1.5	1.5	12.5
450 NSA 225	450.000 450.116	475	50	124.6 125.4	32.1	225	35	1.5	1.5	12.5
500 NSA 250	500.000 500.120	532	55	139.6 140.4	50.9	250	35	2	2	16
560 NSA 280	560.000 560.120	600	65	149.5 150.5	80.0	280	50	2	2	20
630 NSA 315	630.000 630.126	670	75	164.5 165.5	101	315	50	2	2	20

M8 lifting holes provided from size 400 NSA 200 upwards.

Dimensions in mm



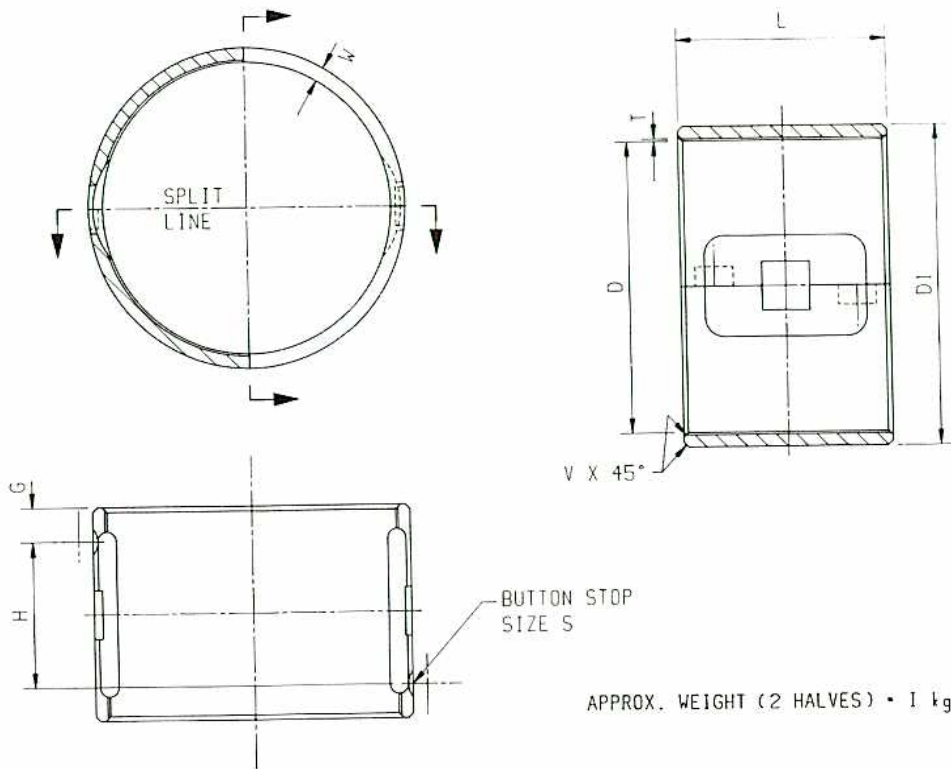
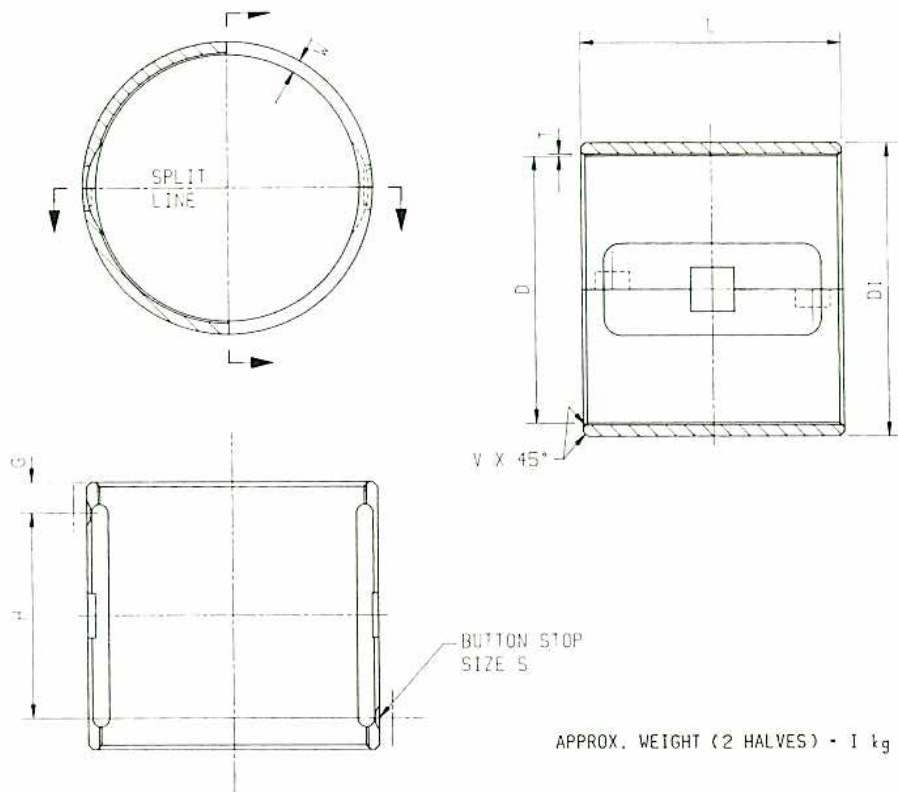

**Table 7 Medium Wall Bearings L/D = 0.75**

Size	D	D <sub>1</sub>	G	H	I	L	S	T	V	W
100 NSA 075	100.000 100.056	110	7	60.75 61.25	0.97	75	12	1	1	5
110 NSA 080	110.000 110.056	120	9.5	60.75 61.25	1.1	80	12	1	1	5
125 NSA 095	125.000 125.059	135	10	74.75 75.25	1.5	95	12	1	1	5
140 NSA 105	140.000 140.059	150	15	74.75 75.25	1.9	105	12	1	1	5
160 NSA 120	160.000 160.059	170	15	89.75 90.25	2.4	120	12	1	1	5
180 NSA 135	180.000 180.063	192	20	94.75 95.25	3.7	135	16	1	1	6
200 NSA 150	200.000 200.067	212	20	109.75 110.25	4.6	150	16	1	1	6
225 NSA 170	225.000 225.067	241	25	119.75 120.25	7.8	170	16	1	1	8
250 NSA 190	250.000 250.070	266	30	129.75 130.25	9.7	190	16	1	1	8
280 NSA 210	280.000 280.070	296	35	139.75 140.25	11.9	210	16	1	1.5	8
315 NSA 235	315.000 315.086	335	35	164.6 165.4	18.8	235	20	1.5	1.5	10
355 NSA 265	355.000 355.086	375	40	184.6 185.4	29.6	265	20	1.5	1.5	10
400 NSA 300	400.000 400.090	425	45	209.6 210.4	38.1	300	25	1.5	1.5	12.5
450 NSA 340	450.000 450.116	475	50	239.6 240.4	48.4	340	35	1.5	1.5	12.5
500 NSA 375	500.000 500.120	532	55	264.6 265.4	76.3	375	35	2	2	16
560 NSA 420	560.000 560.120	600	65	289.5 290.5	120	420	50	2	2	20
630 NSA 470	630.000 630.126	670	75	319.5 320.5	151	470	50	2	2	20

M8 lifting holes provided from size 400 NSA 300 upwards.

Dimensions in mm



**Table 8 Medium Wall Bearings L/D = 1.0**

Size	D	D <sub>1</sub>	G	H	I	L	S	T	V	W
100 NSA 100	100.000 100.056	110	7	85.75 86.25	1.3	100	12	1	1	5
110 NSA 110	110.000 110.056	120	9.5	90.75 91.25	1.6	110	12	1	1	5
125 NSA 125	125.000 125.059	135	10	104.75 105.25	2.0	125	12	1	1	5
140 NSA 140	140.000 140.059	150	15	109.75 110.25	2.5	140	12	1	1	5
160 NSA 160	160.000 160.059	170	15	129.75 130.25	3.3	160	12	1	1	5
180 NSA 180	180.000 180.063	192	20	139.75 140.25	4.9	180	16	1	1	6
200 NSA 200	200.000 200.067	212	20	159.75 160.25	6.1	200	16	1	1	6
225 NSA 225	225.000 225.067	241	25	174.75 175.25	10.3	225	16	1	1	8
250 NSA 250	250.000 250.070	266	30	189.75 190.25	12.7	250	16	1	1	8
280 NSA 280	280.000 280.070	296	35	209.75 210.25	15.9	280	16	1	1.5	8

*Dimensions in mm*



# Enquiry Data Sheet for Waukesha Medium or Thick Wall Journal Bearing

Photocopy this page, complete data and send to:

**Fax to Waukesha Bearings: +44 (0)1923 845160 (Europe) OR +1 262 506 3001 (USA)**  
**Or e-mail: eurosales@waukbearing.com (Europe) OR sales@waukbearing.com (USA)**

Please confirm bearing selection,  
bore profile and estimated operating data  
for the following:

Your Name:

Project Ref:

Company:

Fax No. for reply:

## 1 General

application \_\_\_\_\_

size code \_\_\_\_\_

or shaft dia \_\_\_\_\_ mm

likely quantity \_\_\_\_\_

medium or thick wall? \_\_\_\_\_

## 2 Radial Load

normal \_\_\_\_\_ N

max continuous \_\_\_\_\_ N

at instant of start up \_\_\_\_\_ N

direction \_\_\_\_\_ ° from BDC

steady or rotating? \_\_\_\_\_

## 3 Axial Load – if present

normal \_\_\_\_\_ N

max continuous \_\_\_\_\_ N

at instant of start up \_\_\_\_\_ N

## 4 Lubricant

type \_\_\_\_\_

or ISO viscosity grade \_\_\_\_\_

or viscosity at stated temperature \_\_\_\_\_

temperature at bearing inlet \_\_\_\_\_ °C

pressure at bearing inlet \_\_\_\_\_ bar

## 5 Shaft Speed

normal \_\_\_\_\_ min<sup>-1</sup>

max continuous \_\_\_\_\_ min<sup>-1</sup>

overspeed (if any) \_\_\_\_\_ min<sup>-1</sup>

## 6 Special Needs

\_\_\_\_\_



## Notes





## Engineered Bearing Solutions

The type of bearing described in this Handbook is one of a complete range of shaft support products which Waukesha manufacture for rotating machinery (turbines, compressors, pumps, gearboxes, motors, generators, couplings, etc).

Some other products in the Waukesha range:

**Equalised and Unequalised Tilting Pad Thrust Bearings.**

**Horizontal Bearing Assemblies, Self Contained and Force Lubricated.**

**Vertical Bearing Assemblies, Self Contained and Force Lubricated.**

**Tilting Pad Journal Bearings, with a choice of Pad Support Designs.**

**Fixed Profile Thrust Washers.**

**Marine Thrust and Line Shaft Units.**

**Bearings for Water and Product Lubrication.**

**Active Magnetic Bearing Systems.**

**Spares, Repairs and Bearings to Customer Drawings.**

**Note:** The information in this Handbook is given in good faith but no guarantee is given or implied in respect of such information. Waukesha products are subject to continued development and Waukesha reserves the right to make changes in the specification and design of their products without prior notice.



*Steam turbine bearing assembly with independent thick wall shell and CuCr backed thrust pads fitted with temperature sensors.*



W231 N2811 Roundy Circle East  
Suite 200, Pewaukee,  
Wisconsin 53072  
USA  
Tel: +1 262 506 3000  
Fax: +1 262 506 3001  
Email: [sales@waukbearing.com](mailto:sales@waukbearing.com)

53-55 The Broadway  
Joel Street  
Northwood  
Middlesex  
HA6 1NZ  
United Kingdom  
Tel: +44(0) 1923 845100  
Fax: +44(0) 1923 845160  
Email:  
[eurosales@waukbearing.com](mailto:eurosales@waukbearing.com)

[www.waukbearing.com](http://www.waukbearing.com)

